

Doulton®

Filtration Data Sheet

Filtration Efficiency

Absolute filtration rating	(defined as > 99.9999%)	0.9 micron
Nominal filtration rating	(defined as 99.99%)	0.5 - 0.8 micron
% Bacteria removal	E.coli	> 99.99%
	Vibrio Cholera	> 99.99%
	Shigella	> 99.999%
% Cyst removal	Salmonella Typhi	> 99.999%
	Klebsiella Terrigena	> 99.999%
% Cyst removal	Cryptosporidium	100%
	Giardia	100%

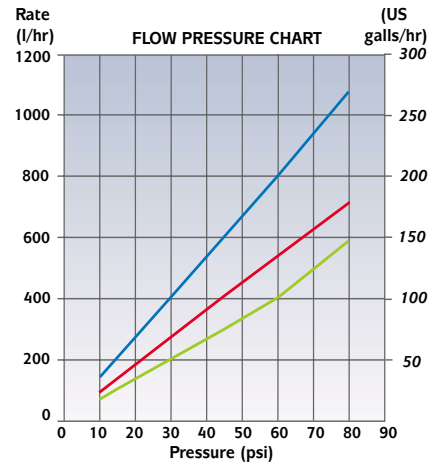

■ 4 1/2 inch diameter Sovereign
■ 2 3/4 inch diameter Imperial
■ 2 inch diameter Slimline

20 Inch Filter Housings

Imperial ceramic (2 3/4") and Sovereign (4 1/2") filter cartridges can be supplied with a second adaptor cartridge to allow fitting in 20 inch filter housings. Due to slight variations in housing design, please state housing manufacturer when ordering.

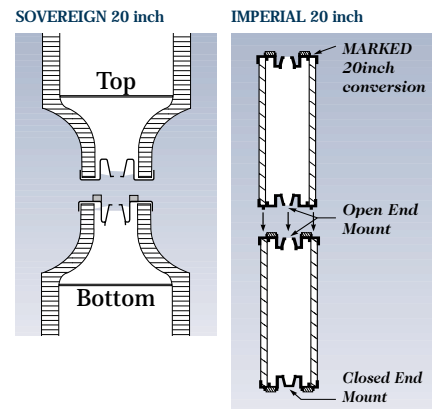

Cartridge Dimensions

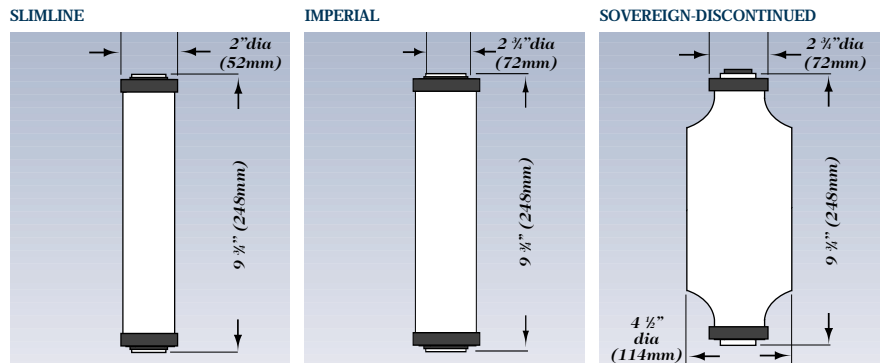

Cartridge Shipping Specification

	Individual cartridge weight	Quantity per outer carton	Outer carton gross weight
Slimline 9 1/4" x 2"	0.2 kg	25	8 kg
Imperial 9 1/4" x 2 3/4"	0.4 kg	9	6 kg
Sovereign 9 1/4" x 4 1/2"	0.8 kg	4	5 kg
Standard carton size 33 x 33 x 34 cm			

Product Specification

Working temperature range	40/5 - 100/38°F/C
Working pH range	5.5 - 9.5
Minimum working pressure	10 psi
Maximum working pressure	125 psi

Distributed by:

Doultonusa.com

1.888.664.3336 in US

248.258.5500 int'l

Due to a policy of continuing product development Fairey Industrial Ceramics Limited reserves the right to change any information without prior notice.

Doulton® water filters are manufactured by Fairey Industrial Ceramics Ltd



BS EN ISO 9002: 1994
Certificate Number: 90082

